

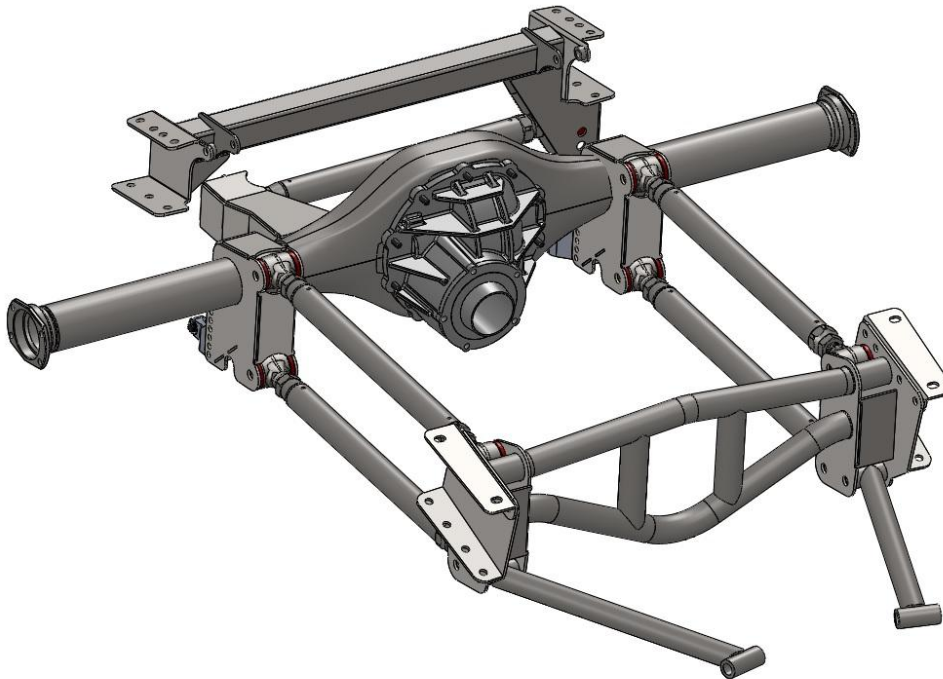

INSTALLATION INSTRUCTIONS

'73-87 CHEVY C-10

4-Link Rear End



Please read these instructions *completely*
before starting your installation.

Assemble suspension on vehicle before powder-coating to ensure proper fitment, and to make modifications if necessary.

For questions on installations please call 800-841-8188 In Illinois (847) 487-0150



PARTS LIST

- | | |
|-------------------------------------|-----------------------------------|
| 1) Forward Crossmember | 4) Control Arm Links |
| 1) Drivers Side Axle Bracket | 1) Passenger Side Axle Bracket |
| 1) Panhard Bracket | 1) Panhard Bar |
| 1) Upper Shock Crossmember | 1) Lower Shock Mount Drivers Side |
| 1) Lower Shock Mount Passenger Side | 2) Forward Struts |
| 2) Adjustable Shocks | 2) Chrome Springs |

2) Forward Strut Chassis Mounts

HARDWARE PACKAGE

- | | | |
|--|---|--|
| 8) $\frac{3}{8}$ Stainless Steel Washers | 44) $\frac{1}{2}$ -20 Nylock Nuts | 28) $\frac{5}{8}$ Washers |
| 2) $\frac{1}{2}$ -20 Nylock Jam Nuts | 14) $\frac{5}{8}$ -18 Nylock Jam Nuts | 4) $\frac{3}{8}$ -24 Nylock Nuts |
| 88) $\frac{1}{2}$ Flat Washers | 2) $\frac{1}{2}$ -20 X $2\text{-}\frac{3}{4}$ Hex Bolts | 44) $\frac{1}{2}$ -20 X $1\text{-}\frac{1}{4}$ Hex Bolts |
| 14) $\frac{5}{8}$ -18 X $3\text{-}\frac{3}{4}$ Hex Bolts | 4) $\frac{3}{8}$ -24 X $3\text{-}\frac{3}{4}$ Hex Bolts | 2) $\frac{1}{2}$ -20 12 Pt. Flange Nuts |
| | 2) $\frac{1}{2}$ -20 X 3 12Pt. Flange Head | |

For questions on installations please call 800-841-8188 In Illinois (847) 487-0150



- 1) Start by jacking up your truck and supporting it on sturdy jack stands. Remove the rear wheels and bed. Disconnect the drive shaft from the rear end. Disconnect the brake lines, emergency brake cables, and fuel tank. Remove the shocks and rear end. **BE SURE TO LABEL ALL HARDWARE FOR RE-INSTALLATION!** At this point the rear end of your truck should be stripped down to the bare frame. Remove cross members and rear end bump stops. Leave the two rear cross members in original position. See **Figures 1 and 2.**

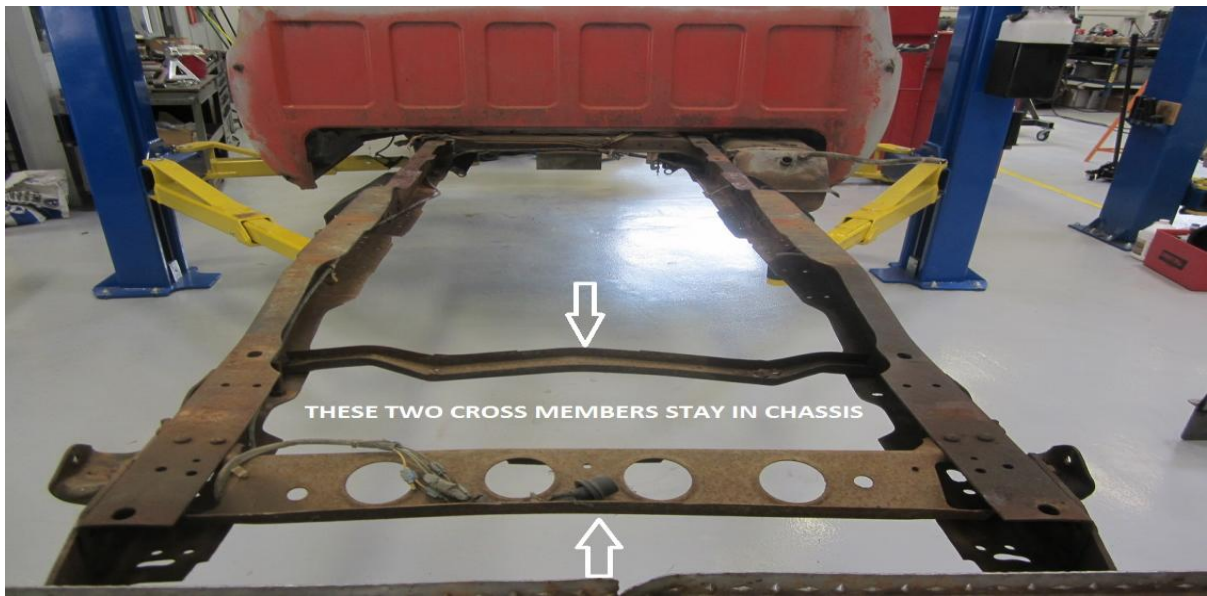

Figure 1



Figure 2

For questions on installations please call 800-841-8188 In Illinois (847) 487-0150



- 2) The first part to install is the Front Crossmember. Prior to installation the frame rails will need to be slightly ground for fitment. **Figure 3** shows the factory cross member that will need to be removed for the installation of the four link front cross member. Once that Crossmember is removed eight rivet holes will be on top and bottom of the frame rails. **The holes on the bottom of the frame rail are critical for the installation of the front Crossmember. Figures 4 and 5** also show the areas on both sides of the chassis that need to be ground. Those areas are above and forward of the factory leaf spring mount. Grind approximately 3/16" on both sides to get started. **See Figures 3-5.**



Figure 3



Figure 4 Drivers Side

For questions on installations please call 800-841-8188 In Illinois (847) 487-0150



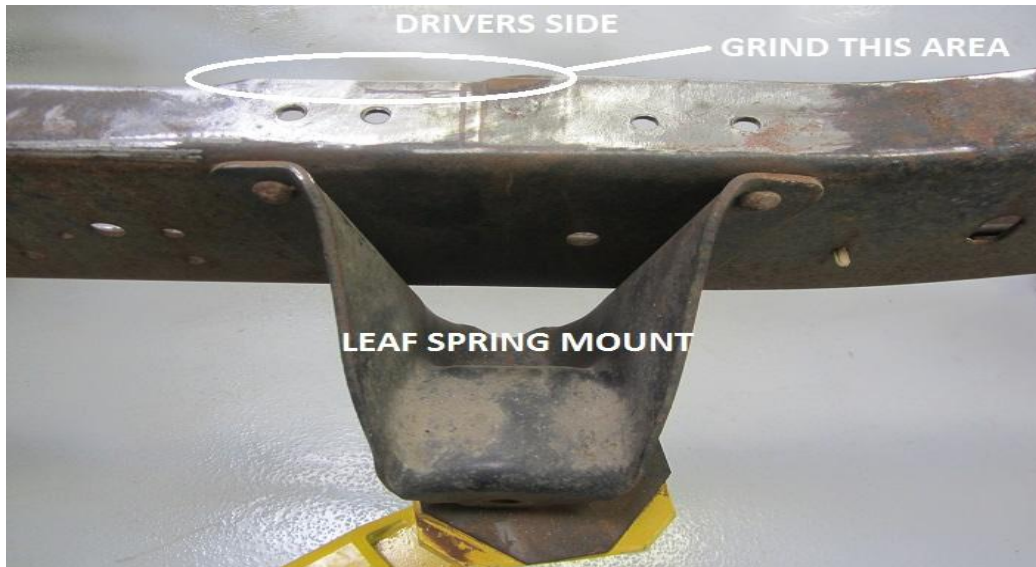

Figure 5 Passenger Side

- 3) After the frame rails are ground for clearance, place the front Crossmember up in the chassis as shown in **Figure 6**. Use clamps to hold the Crossmember in the chassis. There should be four holes on the bottom frame rail on both sides where the factory Crossmember that was cut out. Align the bottom of the new Crossmember mounting holes with the ONE rivet hole closest to the factory spring mount. See **Figure 7**.

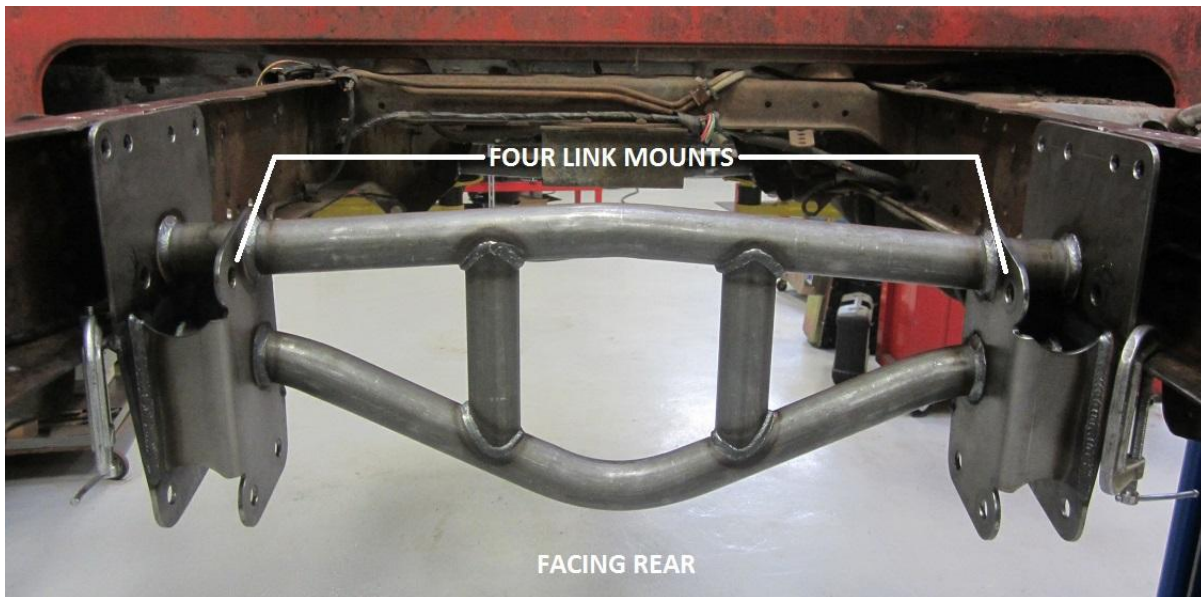

Figure 6

For questions on installations please call 800-841-8188 In Illinois (847) 487-0150

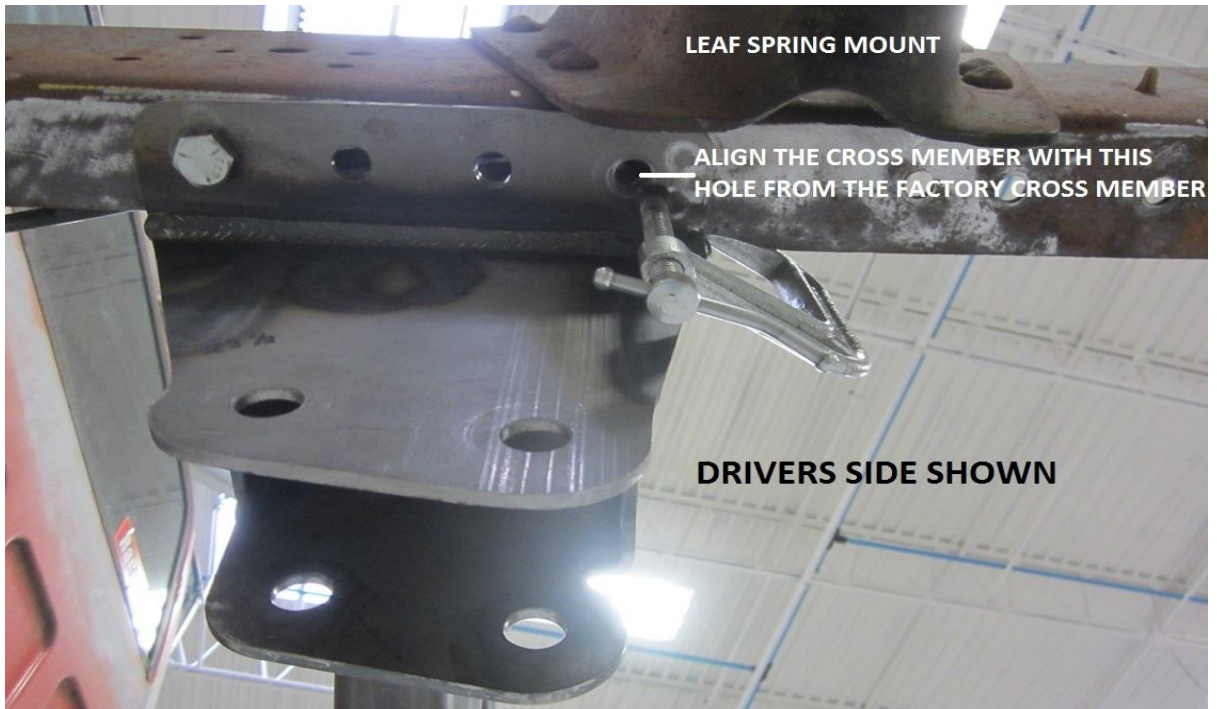

Figure 7

- 4) To do a double check, place a square in the center of the leaf spring mount rivet shown in **Figure 8**. Measure from the Crossmember to the square. Our Measurement came out to be 3 ¾" from the Crossmember to the end of the ruler. There may be little plus and minus across fifteen years, ('73-87) however it is important to check both sides until there is an equal measurement. Check measurements again before drilling. See **Figure 8**.



Figure 8

For questions on installations please call 800-841-8188 In Illinois (847) 487-0150



- 5) Once the Crossmember is in the correct location, it is time to drill all the mounting holes. There are four mounting holes on the bottom of each side. The alignment hole we used in Step 3 can be drilled first on both driver and passenger sides. Drill the two holes to $\frac{1}{2}$ ". Insert a $\frac{1}{2}$ -20 x $1\frac{1}{2}$ " grade 8 bolt with a nylock nut on each side to hold the Crossmember in place. Drill all other holes to $\frac{1}{2}$ ". Use a center punch and pilot drill before drilling to $\frac{1}{2}$ ". See **Figures 9 and 10**.



Figure 9



Figure 10

- 6) Install the front crossmember using eight $\frac{1}{2}$ -20 x $1\frac{1}{2}$ " grade 8 bolts, washers and nylock nuts. Four bolts on each side. **DO NOT TIGHTEN** until the top bolts are installed.
- 7) Install the chassis brackets as shown in **Figures 11-19**. **Figure 11** shows the drivers side and **Figure 12** shows the passenger side. Bolt the drivers side bracket to the crossmember shown in **Figure 13**.

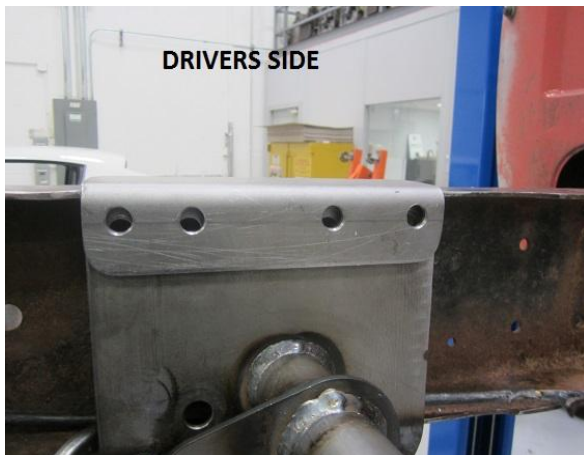

Figure 11

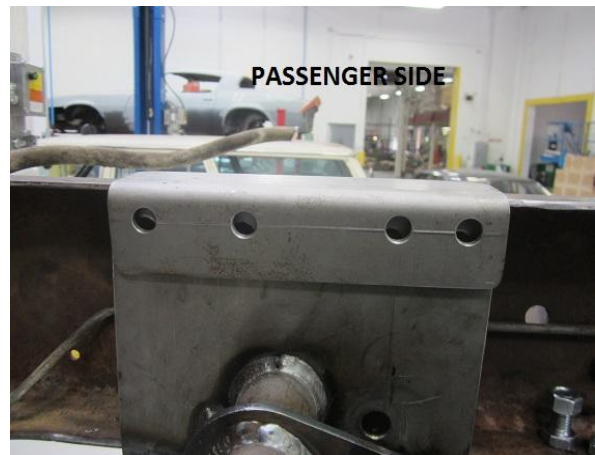

Figure 12

For questions on installations please call 800-841-8188 In Illinois (847) 487-0150



- 8) With the upper brackets installed, use a ruler and scribe the lines for the upper mounting bolts. Measure from the center of the rivet hole from the factory Crossmember and scribe a line at 2 ½" and another at 5". These scribe lines will be the locations of the other holes for the mounting bracket. See **Figure 14**.

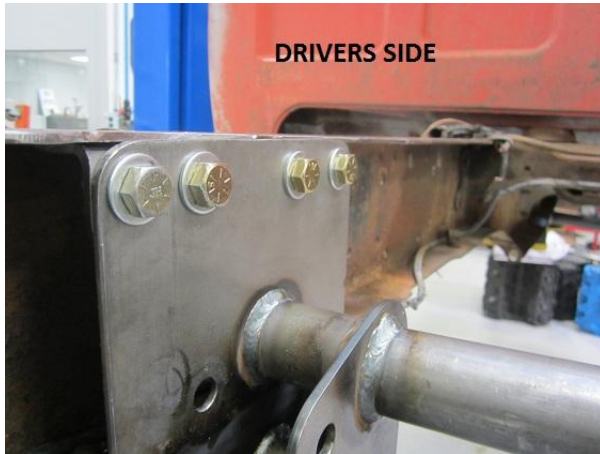

Figure 13

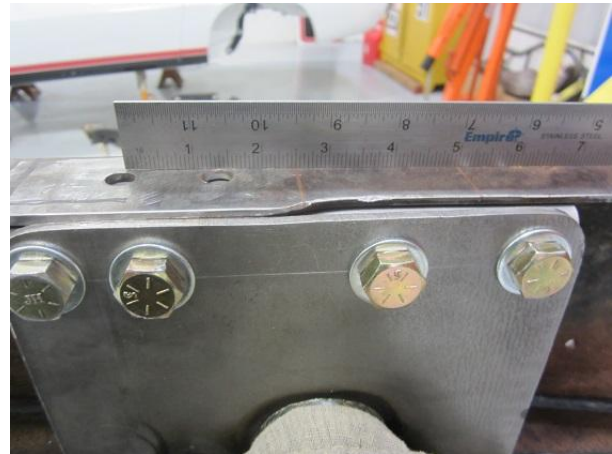

Figure 14

- 9) With the lines scribed the holes and can located and drilled. Use a center punch to start the holes as seen in **Figure 15**. Use a 1/8" pilot drill first followed by a 3/8" for ease of ½" drilling. See **Figures 15 and 16**.

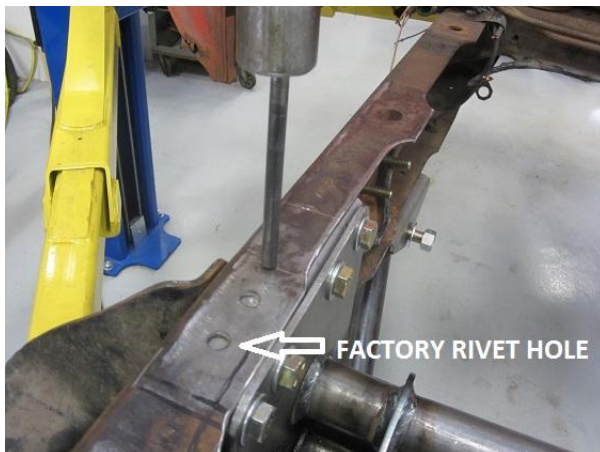

Figure 15



Figure 16

For questions on installations please call 800-841-8188 In Illinois (847) 487-0150



10) After the holes are pilot drilled, drill all holes to $\frac{1}{2}$ ". The factory rivet hole needs to also be drilled to $\frac{1}{2}$ ". Use $\frac{1}{2}$ -20 x 1 $\frac{1}{2}$ " grade 8 bolts, washers and nylock nuts supplied in the hardware kit to bolt the bracket to the frame rail and Crossmember. ALL NUTS AND BOLTS CAN NOW BE TIGHTENED. See **Figures 17-19**.



Figure 17

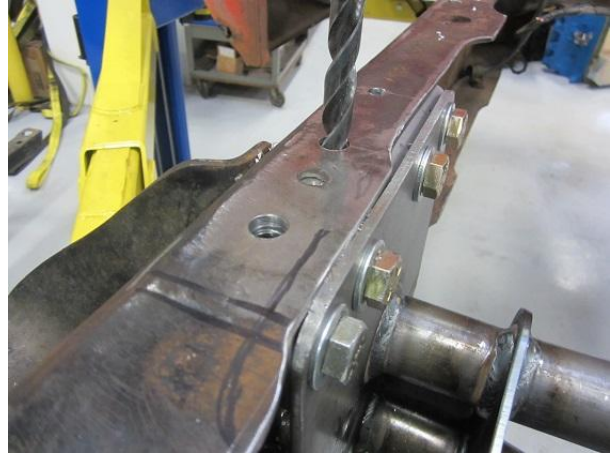

Figure 18



Figure 19

For questions on installations please call 800-841-8188 In Illinois (847) 487-0150



11) With the front crossmember bolted in the Forward Struts can now be installed. Bolt the Forward Strut to the front Crossmember as seen in **Figure 20** using 5/8-18 x 3 3/4" bolt, washers and nylock jam nut. Bolt the Forward Strut mount to the Forward Strut using 5/8-18 x 3 3/4" bolt, washers and Nylock nut. See **Figures 20 and 21**.



Figure 20



Figure 21

12) Push the Forward Strut with the mount up to the frame rail. Center punch the 1/2" holes of the mount to the frame. Pilot drill and drill the 1/2" holes to the frame. See **Figures 22 and 23**.



Figure 22



Figure 23

For questions on installations please call 800-841-8188 In Illinois (847) 487-0150



- 13) Bolt the Forward Strut Mount to the frame using $\frac{1}{2}$ -20 x 1 $\frac{1}{2}$ " grade 8 bolts, washers and nylock nuts. Unbolt the Forward Strut from the mount. Center punch and drill the bottom holes of the Forward Strut Mount. See **Figures 24-26**.



Figure 24



Figure 25



Figure 26

- 14) Repeat Step 13 for the passenger side. Tighten all bolts, washers and nuts and reinstall the Forward Struts to the Strut Mounts.

For questions on installations please call 800-841-8188 In Illinois (847) 487-0150



15) The next part to be installed is the upper shock crossmember. Place the shock crossmember in the chassis and clamp to the frame rails as shown in **Figure 27**.

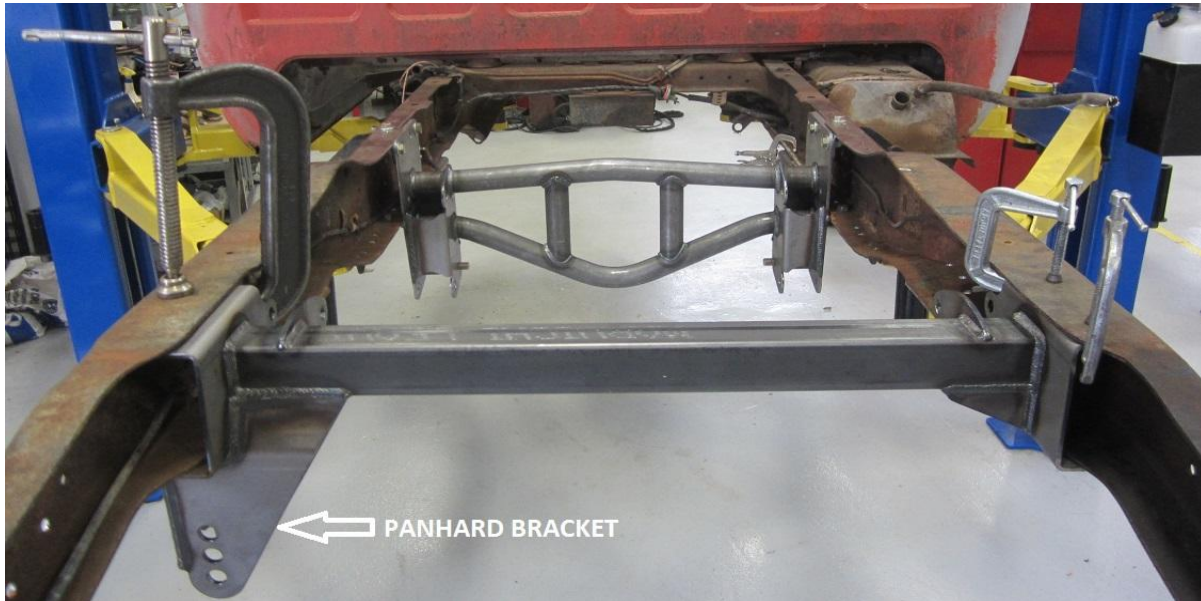

Figure 27

16) With the shock crossmember clamped snug to the frame rails, The crossmember needs to be squared and clamped tight before the $\frac{1}{2}$ " holes can be drilled. Place a straight edge against the front of the lower bracket and measure from the straight edge to the top factory leaf spring mount rivet. The dimension should be $27 \frac{5}{8}$ ". Repeat this step for passenger side. See **Figures 28-31**.



Figure 28

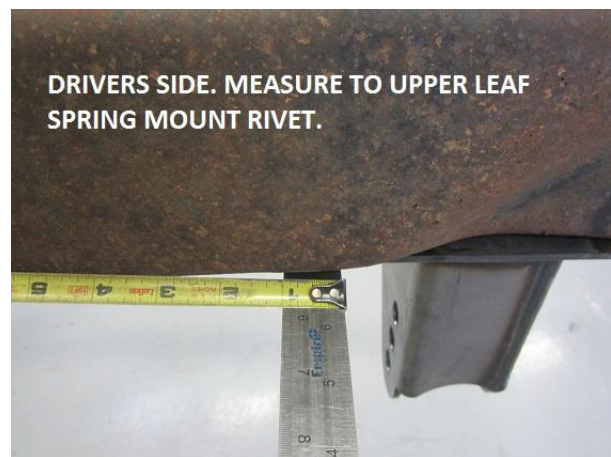

Figure 29

For questions on installations please call 800-841-8188 In Illinois (847) 487-0150



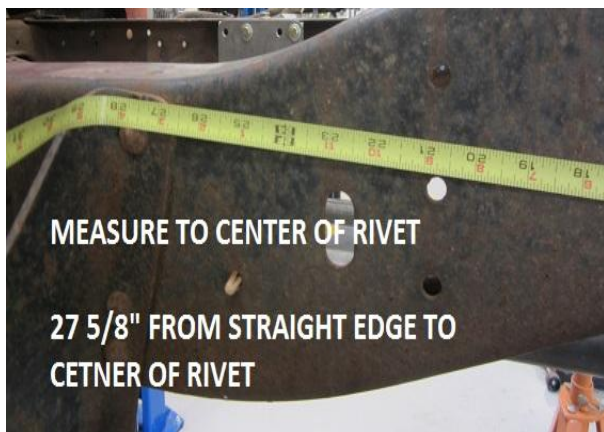

Figure 30



Figure 31

17) Place the straight edge to the rear of the lower mounting bracket. Measure from the straight edge to the center of the middle rivet of the rear leaf spring mount. This dimension should be 15". Repeat this step for passenger side. See **Figures 32-34**.



Figures 32-34

For questions on installations please call 800-841-8188 In Illinois (847) 487-0150



18) Now that the shock crossmember is square front to rear, the side to side dimensions need to be corrected. Measure from the inside of the frame rail to the outside of the inboard shock mount tab. The drivers side dimension should be 5 ½". The passenger side dimension is 5". See **Figures 35 and 36**.

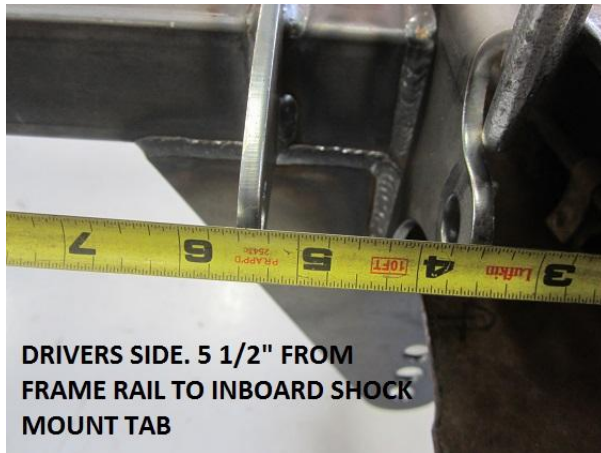

Figure 35

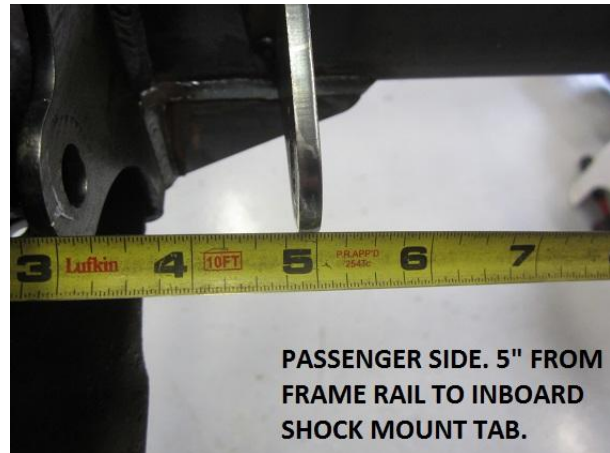

Figure 36

19) After all dimensions are square front to rear and side to side, clamp the shock crossmember tight against the frame rails. Double check all measurements one more time before drilling holes. After all dimensions are checked one last time, center punch all six lower ½" holes to the chassis. After lower holes are punched, remove crossmember and drill all six holes. Start with an 1/8" pilot drill, then use 3/8" bit followed by ½". See **Figures 37 and 38**.



Figure 37

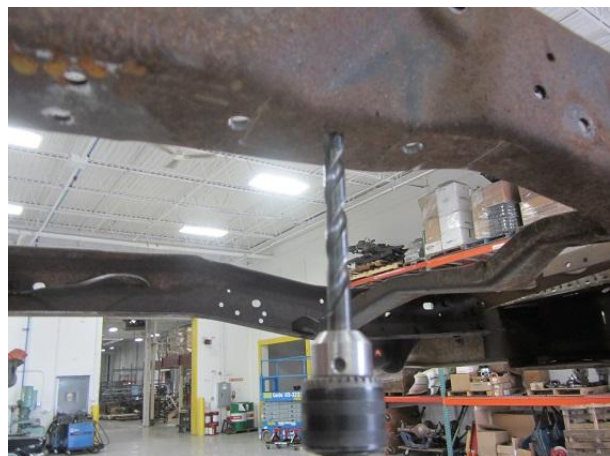

Figure 38

For questions on installations please call 800-841-8188 In Illinois (847) 487-0150



20) After all six holes are drilled $\frac{1}{2}$ ", place the shock crossmember back into the chassis to double check bolt hole alignment. Bolt down the crossmember to the chassis in the four corners. Use $\frac{1}{2}$ -20x $1\frac{1}{4}$ " grade 8 bolts, washers and nylock nuts to complete this step. Using a small square, scribe lines on the top frame rail parallel to the top of the mounting bracket. Repeat this step for the passenger side. See **Figures 39 and 40**.

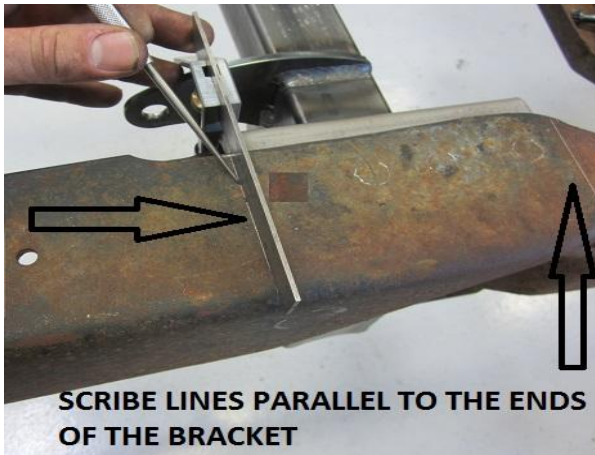

Figure 39



Figure 40

21) After all four lines are scribed, flip crossmember upside down and reversed driver to passenger side. Align the brackets with the scribe lines previously scribed. Once the brackets are aligned clamp the crossmember snug to the frame rail. See **Figures 41 and 42**.

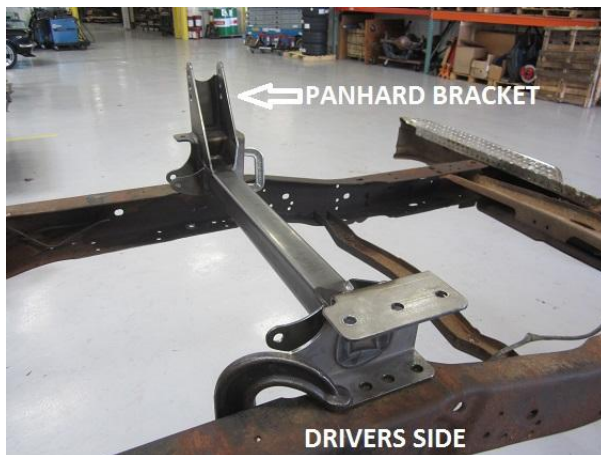

Figure 41

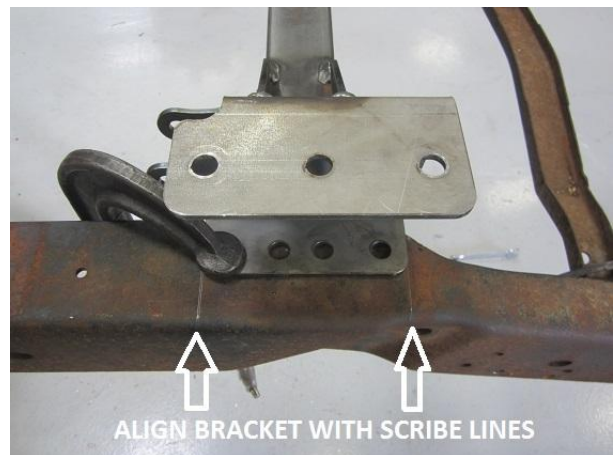

Figure 42

For questions on installations please call 800-841-8188 In Illinois (847) 487-0150



22) After the shock crossmember is squared to the scribe line, measure from the inside of the frame rail to the inboard shock mount **repeating Step 18**. The side to side dimensions are: 5 ½" from frame rail to inboard shock tab on drivers side, and 5" inside frame rail to inboard shock tab on passenger side. **Double check all dimensions**. See **Figure 43**. Once the side to side dimensions are true, clamp the crossmember tight and scribe the 8 holes to the top frame rail. See **Figure 44**.



Figure 43

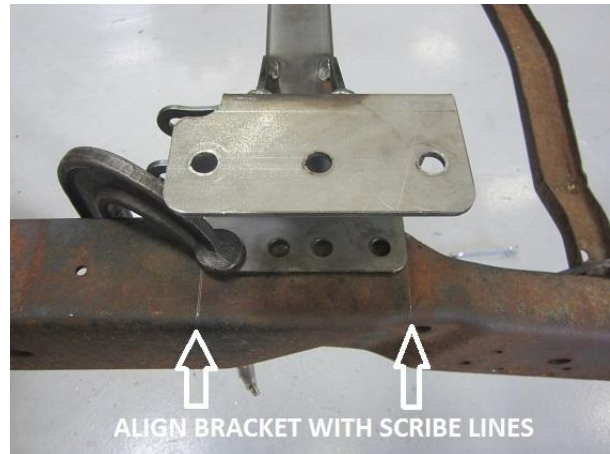

Figure 44

23) Once all 8 holes are scribed to the top frame rail, remove the shock crossmember and center punch the scribed holes. See **Figure 45**. Drill the holes by using a 1/8" pilot drill, 3/8" then ½" to complete the shock crossmember mounting holes. See **Figures 45-48**.

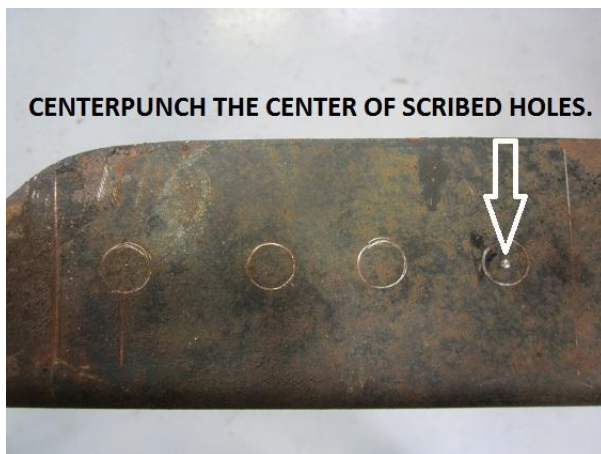

Figure 45



Figure 46

For questions on installations please call 800-841-8188 In Illinois (847) 487-0150





Figure 47



Figure 48

24) Bolt the shock crossmember into the frame using 14 ½-20x 1 ¼" grade 8 bolts, washers and nylock nuts. If upper mounting holes are slightly off, we recommend using a C clamp to move the frame rail in closer to the holes. See **Figure 49**.



Figure 49

For questions on installations please call 800-841-8188 In Illinois (847) 487-0150



25) Install the passenger side rear shock. (**Figure 50**) Use a sharpie to mark the frame for spring clearance. Uninstall the shock and grind away the marked area. We recommend using a sanding drum for this step. Repeat this step for grinding the drivers side. See **Figures 50-54**.



Figure 50



Figure 51



Figure 52



Figure 53



Figure 54

For questions on installations please call 800-841-8188 In Illinois (847) 487-0150



26) Set all four link bars to 25 1/2" center to center from the bolt holes. This will be the starting point when aligning the rear end. Install the two lower links using two 5/8-18 x 3 3/4" bolts, four washers and two 5/8-18 jam nuts. Install the Ford 9" housing using stands on each axle tube. **Connect the lower links to the housing finger tight. This will ease installation of the rear sway bar later.** Grease fittings on bushings should be facing up. See Figures 55 and 56.



Figure 55



Figure 56

For questions on installations please call 800-841-8188 In Illinois (847) 487-0150



27) Install the two upper links using two 5/8-18 x 3 3/4" bolts, four washers and two 5/8-18 jam nuts. Grease fittings on the upper link bushings should be facing down. Opposite of lower link grease fittings. See **Figures 57 and 58.**



Figure 57



Figure 58

For questions on installations please call 800-841-8188 In Illinois (847) 487-0150



28) Set the Panhard bar to 24" center to center from the bolt holes. This will be the starting point when aligning the rear end. Install the panhard bar using two 5/8-18 x 3 3/4" bolts, four washers and two 5/8-18 jam nuts. Grease fittings on panhard bushings should be facing up. See **Figure 59**.



Figure 59

29) After rear end housing and Panhard bar are installed, it's time to square the rear end. First using a floor jack or stands lift the rear end housing till the panhard bar and upper and lower links are dead level.

30) Now that the rear end housing is level with the panhard bar, you can measure from the face of the rear end housing to a rivet on the factory leaf spring mount. There are many places on the factory frame to utilize, however we are going to use this rivet in **Figure 61** to square this rear end housing. Same rivet for passenger side. See **Figures 60 and 61**.



Figure 60



Figure 61

For questions on installations please call 800-841-8188 In Illinois (847) 487-0150



- 31) Measure from the front of the axle tube (**Figure 60**) to the start of the factory rivet (**Figure 61**). Measure both driver and passenger sides and adjust accordingly using the adjustable links. Due to factory tolerances, this dimension should be in the vicinity of 21 1/8" as seen in **Figure 61**.
- 32) To ensure rear end housing is square side to side, we will measure from the outer frame rail directly above the axle tube to the outside of the axle flange. Use a straight edge on the axle flange and a tape measure for this step. Make adjustments from the panhard bar until both driver and passenger side are the same dimensions. Dimensions will vary with different track width rear ends. See **Figure 62** for example.



Figure 62

- 33) After the rear end is squared there needs to be frame clearance for the four link mounts. The steps are similar to the shock clearance step 25. Lift the rear end housing till the mounts hit the lower frame and mark with a sharpie. **The rear end housing and links will need to be removed before cutting frame rail.** Cut away the frame using a cutting wheel. See **Figures 63-68**.

For questions on installations please call 800-841-8188 In Illinois (847) 487-0150





Figure 63



Figure 64



Figure 65



Figure 66

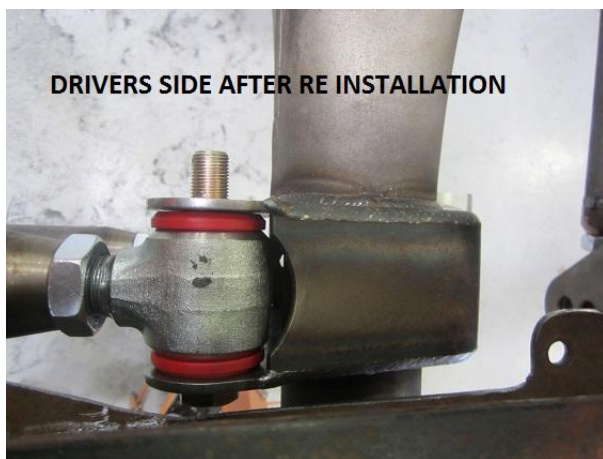

Figure 67



Figure 68

For questions on installations please call 800-841-8188 In Illinois (847) 487-0150



34) *****Install rear sway bar before installing shocks. See IN-188.*****

35) Set the shocks at 13 ½" center to center from the bolt hole. Once the shocks are assembled, install the shocks to the upper shock mount first. The upper shock mount spacer is mounted on the outboard side. This is to keep the shock straight up and down. See **Figure 69**.

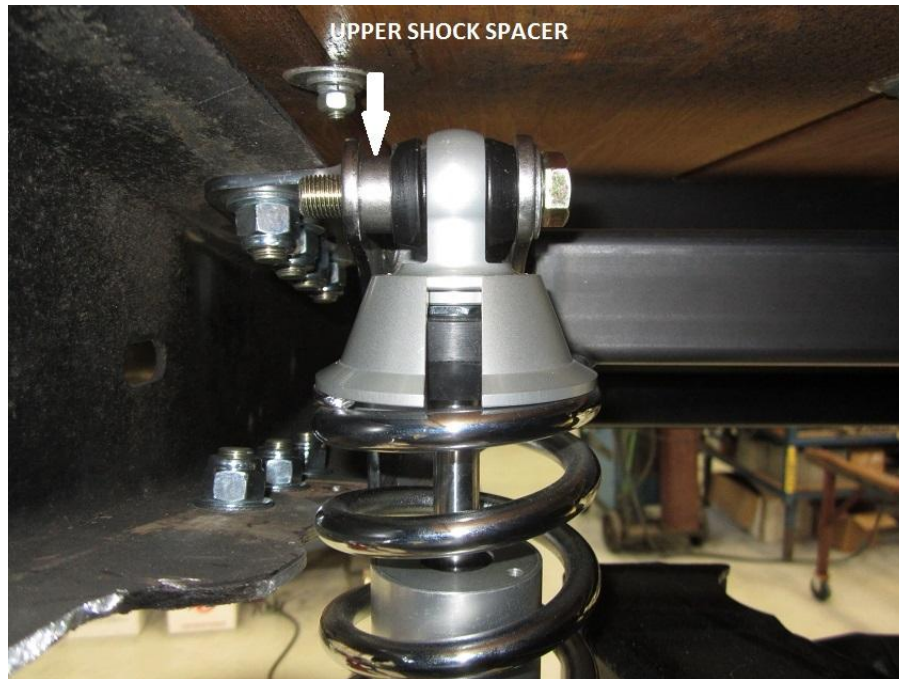

Figure 69

36) Install aluminum lower shock mount to the rear end housing. Use the 3/8-24 x 3 ½" grade 8 bolts, 3/8-24 nylock nuts and washers. See **Figure 70**.



Figure 70

For questions on installations please call 800-841-8188 In Illinois (847) 487-0150



37) Complete the shock installation by bolting the shock to the lower shock mount using $\frac{1}{2}$ -20 X 3 12Pt. Flange Head bolts and $\frac{1}{2}$ -20 12 Pt. Flange Nuts. Make sure adjuster faces towards the rear of the truck. **KEEP FLANGE BOLT LOOSE FOR BUMP STOP INSTRUCTION STEP 39.** See **Figures 71 and 72.**

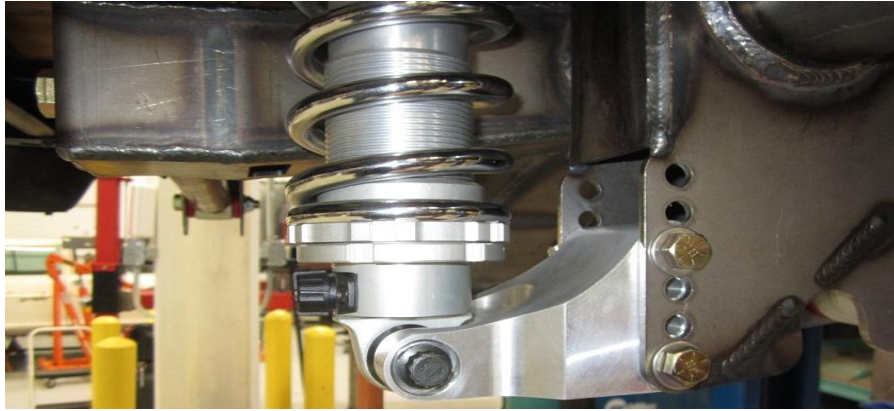

Figure 71

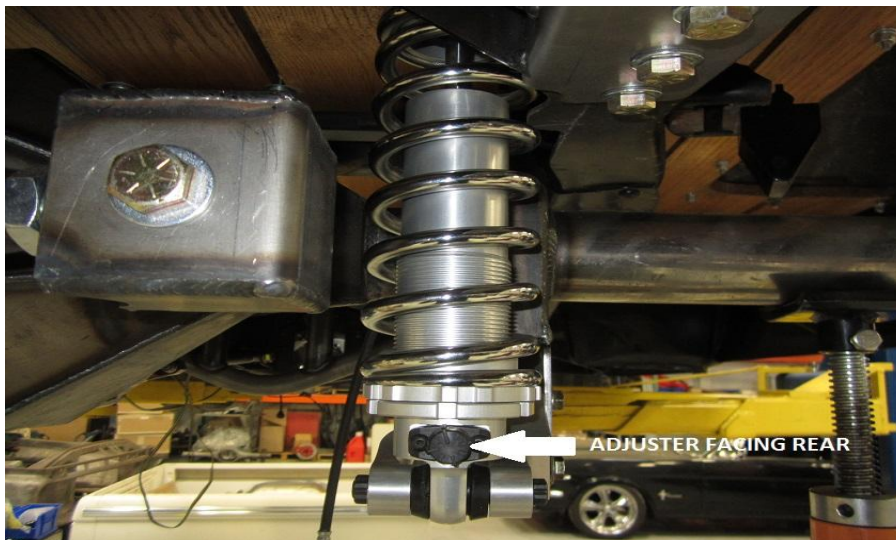

Figure 72

38) Install both shocks so both adjusters are facing out. This is for ease of adjustment.
*****Make sure all nuts and bolts are tightened before driving on the road.*****
See **Figure 73.**

For questions on installations please call 800-841-8188 In Illinois (847) 487-0150



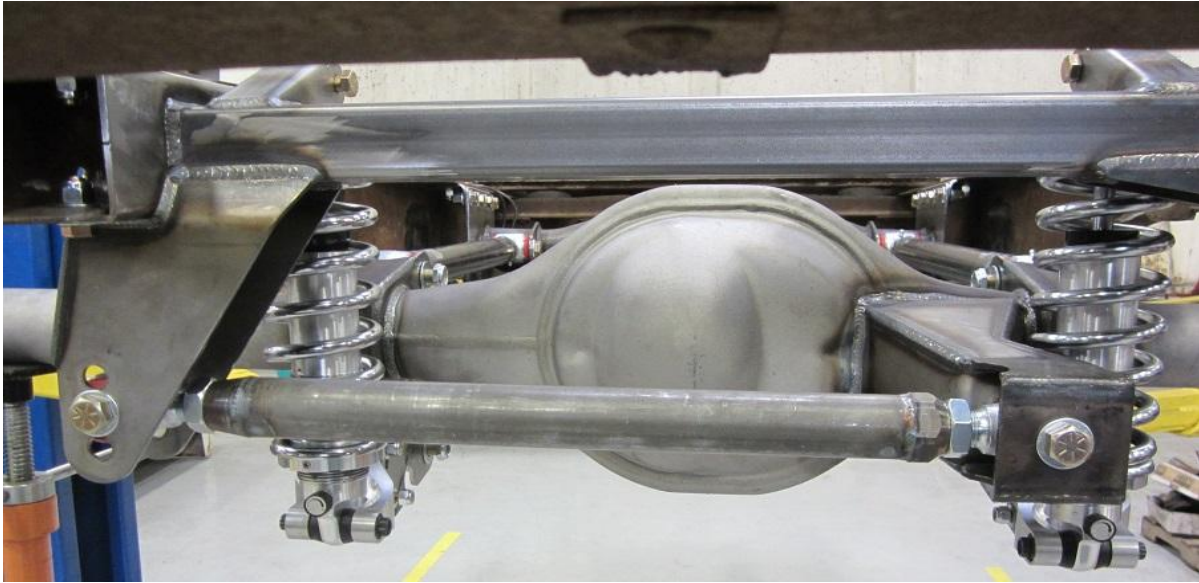

Figure 73

39) Disconnect the lower shock mount from the aluminum shock mount. Raise the rear end housing till the housing touches the chassis. Scribe lines around the axle tubes to the chassis. See **Figures 74-75**.



Figure 75



Figure 76

40) Once the lines are scribed, remove the rear end housing from the chassis. Measure $1\frac{1}{2}$ " from either one of the scribe lines (Center of scribe lines) and scribe another mark. This will determine where the bump stop will be installed. Approximately halfway between the sides of the chassis make another scribe mark. Center punch where the scribe lines meet. Pilot drill and drill to $\frac{3}{8}$ ". Install bump stop. See **Figures 77-82**.

For questions on installations please call 800-841-8188 In Illinois (847) 487-0150



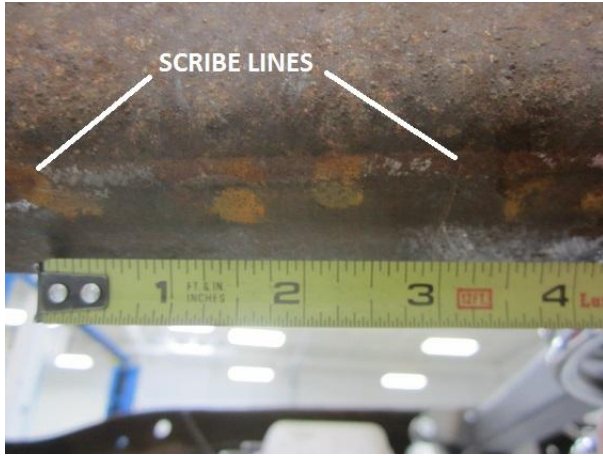

Figure 77



Figure 78



Figure 79



Figure 80



Figure 81



Figure 82

For questions on installations please call 800-841-8188 In Illinois (847) 487-0150



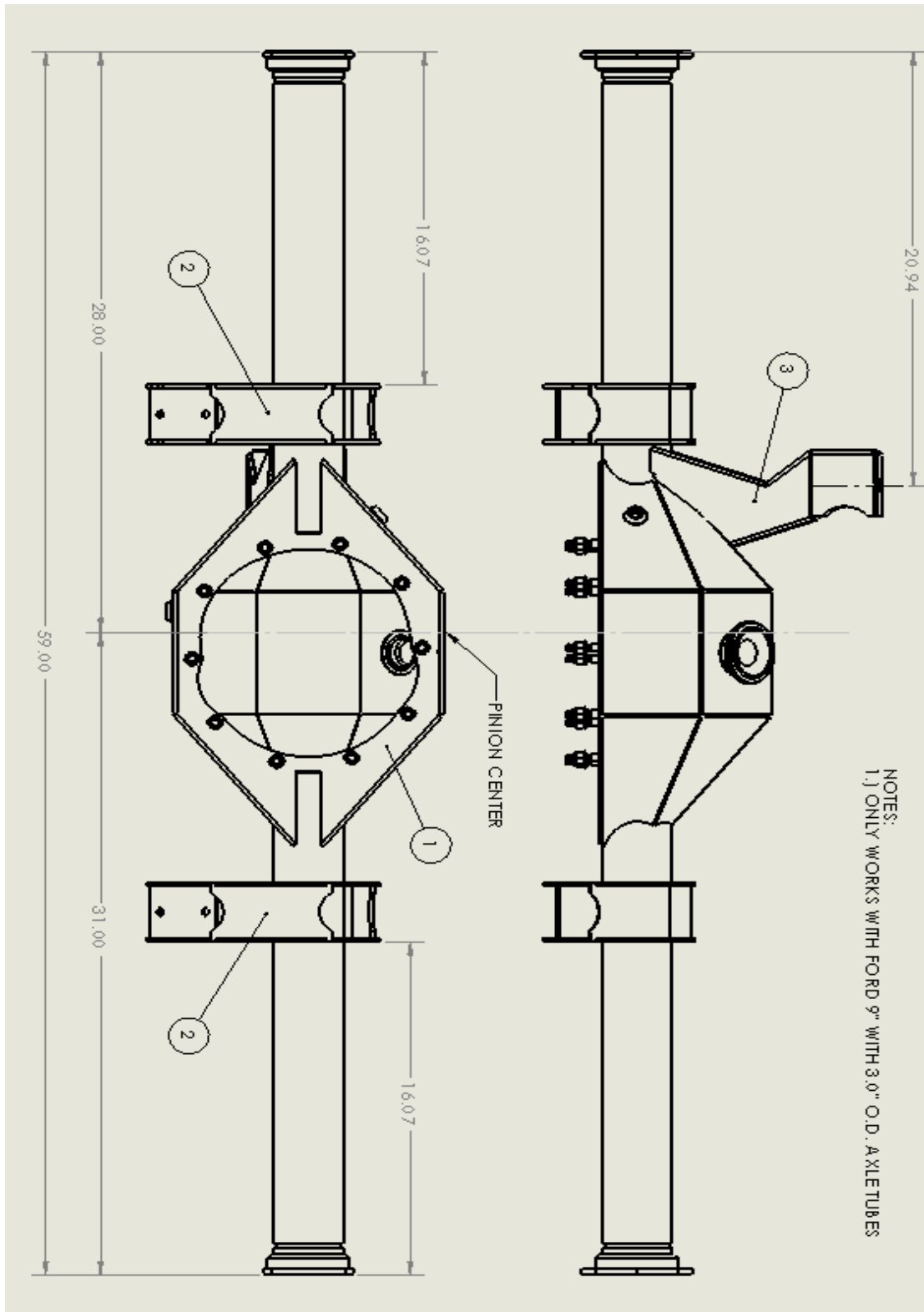

For questions on installations please call 800-841-8188 In Illinois (847) 487-0150



Since you are now to the point where you have a finished, running truck (we hope!) it is time to test drive it. After a few hundred miles, double check the ride height and the alignment. The springs may have settled, which would change the ride height. Re adjust the ride height before changing the alignment. After this initial settling period, the springs and bushings should have taken their final set, so you should be on your way to many miles of cruising in style.

For questions on installations please call 800-841-8188 In Illinois (847) 487-0150

